

Standard configuration	Optional device	Attachments
Wide view standard mast	3-stage full free mast	Side shifter
Class II/III standard carriage	2-stage full free mast	Side shifting fork positioner
Load backrest	Wide carriage	Cargo boom
Control valve	Long forks	Lifting hook
Battery	Fork extension sleeve	Paper roll clamp
Standard seat	Solid tires	Bale clamp
Overhead guard	Widen tires	Multifunction clamp
Overhead guard rain cover	Warning light	Load stabilizer
Pneumatic tires	Rear working light	Push pulls
Traction pin	Tilt/steering cylinder boot	Drum clamp
Driver's tool	Cab	Rotator
LCD combination instrument	Suspension seat	Carton clamp
Head light	Customer color	Battery lifting sling
LED signal light	Coloring tires (white/green)	
Rear handle with horn	Automatic steering slow down device	

* Details of specifications and equipment are based on information available at time of printing and may change without notice.

ANHUI HELI CO., LTD.
 ADD: NO.668 Fangxing Street, Economical Development Zone, Hefei, P.R. China
 TEL: (86 551) 63639068 (America) 63639258 (Europe) 63639358 (Asia)
 63642105 (Africa & Middle East) 63639530 (Key Accounts division)
 63639531 (Wheel loader)
 FAX: (86 551) 63639966
 WEBSITE: <http://www.heliforklift.net>
 Email: heli@helichina.net

AUTHORIZED DEALER

Catalog No.190509 Forklift Print



1-2.5 t G series AC Electric Forklift Truck

1-2.5 t G series AC Electric Forklift Truck



Excellent Visibility

- > Compact structure of mast and driver's view 6% improved.
- > Steering handwheel with 300mm diameter and right installation of meter effectively increase the front view.
- > Large arc shape of the overhead guard and grid tray with proper angle increase operator's upward view.

Better Stability & More Safety

- > New type drive axle and small front overhang design. Longitudinal Stability of the forklift increases by 4.9%.
- > High installation of rear axle increasing transversal stability 2.1%.
- > The space above driver's head is 50mm increased through increasing overhead guard's height and decreasing the seat's height.
- > The space around the driver's foot and operating safety are increased through moving the tilting cylinder to be under the floor board.
- > Multi speed selection function satisfies different working conditions and environment;
- > Standard configuration of warning light and brake automatic warning function improve whole truck's safety.
- > Battery side-extraction function satisfies different customers' needs (optional).
- > Automatic decelerating while steering improves safety (optional).
- > Special side plate and top cover structure is easy for assembly and disassembly.



Option battery side pulling

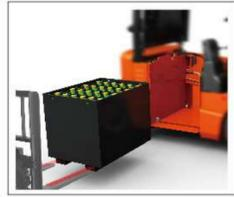

Option battery side loading



High Performance & Energy Saving

- > Lifting performance increases by 21%.
- > Climbing and driving performance increase by 20% and 7%.
- > The maximum turning radius is 2020mm, good performance of driving.
- > The minimum turning radius is 1800mm(1-1.8t), 2000mm(2t) and 2020mm(2.5t), good performance of driving.
- > Travelling saves more than 10% energy.
- > LED signal light saves more than 80% energy.
- > Battery cruising ability prolongs about 30 minutes.

Comfortable Operating & Lower Noise

- > Comfortable operating is achieved through moving the steering unit up and 190mm increased operating space around driver's foot.
- > Rear handle with horn function contributes to stable sitting pose when travelling backward and driving comfort and safety.
- > Mast buffer, rear axle buffer and rear extension type valve operation knob increase operating comfort effectively.
- > Ratchet type hand brake facilitates comfort driving.
- > Big getting on and off handle fits different figure size.
- > Ear noise reduces 1 db.

1-2.5t G series AC Electric Forklift Truck



Manufacturer's Data and Design Characteristics

character		HELI										
		CPD10	CPD15	CPD18	CPD10	CPD15	CPD18	CPD20	CPD25	CPD20	CPD25	
1.01	manufacturer	HELI										
1.02	model	CPD10	CPD15	CPD18	CPD10	CPD15	CPD18	CPD20	CPD25	CPD20	CPD25	
1.03	configuration number	GC1/GC2(P)	GC1/GC2(P)	GC1/GC2(P)	GD1/GD2/GD3(P)	GD1/GD2/GD3(P)	GD1/GD2/GD3(P)	GC1/GC2(P)	GC1/GC2(P)	GD1/GD2/GD3(P)	GD1/GD2/GD3(P)	
1.04	rated capacity	Q kg	1000	1500	1750	1000	1500	1750	2000	2500	2500	
1.05	load center distance	c mm	500	500	500	500	500	500	500	500	500	
1.06	power mode		Battery	Battery	Battery	Battery	Battery	Battery	Battery	Battery	Battery	
1.07	driving mode		Seated	Seated	Seated	Seated	Seated	Seated	Seated	Seated	Seated	
1.08	wheel base	L1 mm	1380	1380	1380	1380	1380	1550	1550	1550	1550	
tyre												
2.01	tyre type		Pneumatic	Pneumatic	SE/Pneumatic	Pneumatic	Pneumatic	SE/Pneumatic	Pneumatic	Pneumatic	Pneumatic	
2.02	wheel number(front/rear)		2/2	2/2	2/2	2/2	2/2	2/2	2/2	2/2	2/2	
2.03	front wheel base	W3 mm	910	910	910	910	910	960	960	960	960	
2.04	rear wheel base	W2 mm	920	920	920	920	950	950	950	950	950	
2.05	tyre (front)		6.00-9-10PR	6.00-9-10PR	6.00-9	6.00-9-10PR	6.00-9-10PR	6.00-9	23 x 9-10-16PR	23 x 9-10-16PR	23 x 9-10-16PR	
2.06	tyre(rear)		16 x 6-8-10PR	16 x 6-8-10PR	16 x 6-8-10PR	16 x 6-8-10PR	16 x 6-8-10PR	18 x 7-8-14PR	18 x 7-8-14PR	18 x 7-8-14PR	18 x 7-8-14PR	
size												
3.01	front overhang	L2 mm	390	390	390	390	390	434	434	434	434	
3.02	mast tilt angle, front/rear	α/β °	6/8	6/8	6/8	6/8	6/8	6/8	6/8	6/8	6/8	
3.03	height with mast retraction	H1 mm	1985	1985	1985	1985	1985	1995	1995	1995	1995	
3.04	free lifting height	H3 mm	155	155	155	155	155	140	140	140	140	
3.05	Max. lifting height	H mm	3000	3000	3000	3000	3000	3000	3000	3000	3000	
3.06	Max. height under working condition	H2 mm	4030	4030	4030	4030	4030	4042	4042	4042	4042	
3.07	overhead guard height	H4 mm	2130	2130	2130	2130	2130	2150	2150	2150	2150	
3.08	fork size:thickness×width×length	T/W/L4 mm	32 × 100 × 770	35 × 100 × 920	35 × 100 × 920	32 × 100 × 770	35 × 100 × 920	35 × 100 × 920	40 × 122 × 920	40 × 122 × 1070	40 × 122 × 920	
3.09	fork arm carrier, DIN standard		2A	2A	2A	2A	2A	2A	2A	2A	2A	
3.10	truck body length (fork excluded)	L' mm	2070	2070	2070	2070	2285	2285	2285	2285	2285	
3.11	truck body width	W1 mm	1086	1086	1086	1086	1086	1185	1185	1185	1185	
3.12	turning radius	r mm	1750	1750	1750	1750	1750	2000	2020	2000	2020	
3.13	clearance between mast and ground	H5 mm	90	90	80	90	90	110	110	110	110	
3.14	clearance between wheel base center and ground (loaded)	H6 mm	95	95	90	95	95	115	115	115	115	
3.15	right angle stacking aisle width (pallet1000x1000mm, clearance 200mm)	Ast mm	3340	3340	3340	3340	3340	3635	3725	3635	3725	
3.16	right angle stacking aisle width (pallet1200x1200mm, clearance 200mm)	Ast mm	3540	3540	3540	3540	3540	3835	3855	3835	3855	
3.17	Lateral Fork Adjustment (Outside of Forks) Max./Min.	W5 mm	960/200	960/200	960/200	960/200	960/200	1030/244	1030/244	1030/244	1030/244	
performance												
4.01	travelling speed: loaded/unloaded	km/h	15/16	15/16	15/16	15/16	15/16	14.5/15	14.5/15	14.5/15	14.5/15	
4.02	lifting speed: loaded/unloaded	m/s	0.29/0.45	0.27/0.45	0.28/0.53	0.41/0.60	0.40/0.60	0.38/0.60	0.28/0.49	0.35/0.51	0.33/0.51	
4.03	lowering speed: loaded/unloaded	m/s	0.50/0.40	0.50/0.40	0.50/0.40	0.50/0.40	0.50/0.40	0.49/0.41	0.49/0.41	0.49/0.41	0.49/0.41	
4.04	gradeability (loaded)	%	24	22	22	20	22	20	20	20	20	
4.05	Max. traction force (loaded)	N	10000	10000	10000	10000	10000	16000	16500	16000	16500	
4.06	acceleration time (10m) loaded/unloaded	s	5.0/4.4	5.2/4.5	5.2/4.6	5.0/4.4	5.2/4.5	5.2/4.6	4.6/4.4	4.8/4.6	4.6/4.4	
weight												
5.01	total weight (with/without battery)	kg	2920/2240	3030/2240	3220/2430	2920/2240	3030/2240	3220/2430	4060/3060	4250/3250	4160/3060	
5.02	axle load: unloaded, front/rear	kg	1508/1412	1505/1525	1493/1727	1508/1412	1505/1525	1493/1727	1860/2200	2000/2250	1900/2260	
5.03	axle load: loaded, front/rear	kg	3150/770	4005/525	4372/598	3150/770	4005/525	4372/598	5270/790	5930/820	5300/860	
battery												
6.01	battery voltage/capacity Ks	V/Ah	48/400(max600)	48/480(max600)	48/480(max600)	48/400(max600)	48/480(max600)	48/480(max600)	48/600(max600)	48/700(max600)	48/700(max600)	
6.02	battery weight	kg	680(600-1000)	790(720-1000)	790(720-1000)	680(600-1000)	790(720-1000)	790(720-1000)	1000(950-1300)	1100(950-1300)	1100(950-1300)	
6.03	battery, DIN standard		43531A	43531A	43531A	43531A	43531A	43531A	43531A	43531A	43531A	
motor and controller												
7.01	drive motor power-60 minutes	kW	8.2	8.2	8.2	8.2	8.2	11.5	11.5	11.5	11.5	
7.02	lifting motor power-S3 15%	kW	7.5	7.5	8.6	10.6	10.6	10.5	10.5	15	15	
7.03	drive motor controlling mode		MOSFET/AC	MOSFET/AC	MOSFET/AC	MOSFET/AC	MOSFET/AC	MOSFET/AC	MOSFET/AC	MOSFET/AC	MOSFET/AC	
7.04	lifting motor controlling mode		MOSFET/DC	MOSFET/DC	MOSFET/DC	MOSFET/AC	MOSFET/AC	MOSFET/AC	MOSFET/DC	MOSFET/DC	MOSFET/AC	
7.05	service brake/parking brake		Hydraulic/Mechanical	Hydraulic/Mechanical	Hydraulic/Mechanical	Hydraulic/Mechanical	Hydraulic/Mechanical	Hydraulic/Mechanical	Hydraulic/Mechanical	Hydraulic/Mechanical	Hydraulic/Mechanical	
7.06	hydraulic system working pressure	Mpa	14.5	14.5	17.5	14.5	14.5	17.5	17.5	17.5	17.5	

NOTE: *Detailed information about battery, please contact our salesmen or engineer. 1. "①" Battery capacity 600Ah for battery side extraction."P" battery side extraction (side pulling or side loading), side pulling for standard. 2. 1: For configuration number, CURTIS Controller; 2: ZAPI Controller; 3: Inmotion Controller.

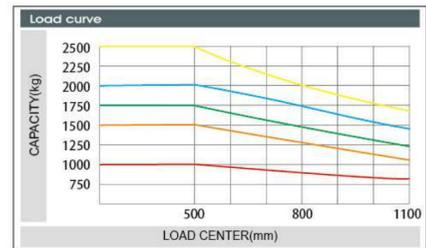
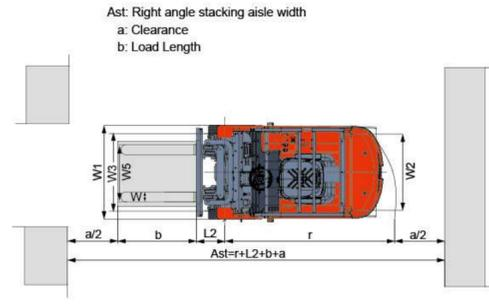
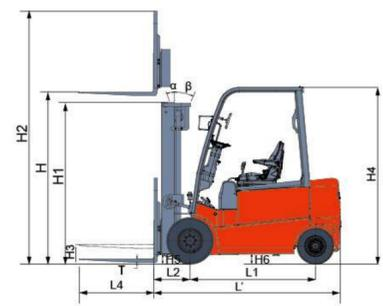

Note: The vertical axis stands for load capacity and the horizontal axis stands for load center which is calculated from the front surface of the forks to the gravity of the standard load. The standard load means a cubic with 1000mm edge length. When mast is tilted forward, using non-standard forks or loading large goods, the load capacity will be reduced. The load capacity of standard mast at different load center can be known from this load chart.

WIDE VIEW MAST

mast model	Max. lifting height (mm)	load capacity (load center 500mm) (kg)					mast overall height (fork to the ground) (mm)		service weight (kg)						mast tilt angle (°) α/β	
		1t	1.5t	1.8t	2t	2.5t	1-1.8t	2-2.5t	1t	1.5t	1.8t	2t(GC)	2t(GD)	2.5t(GC)		2.5t(GD)
M200	2000	1000	1500	1750	2000	2500	1485	1495	2857	2967	3157	3970	4070	4160	4260	6/8
M250	2500	1000	1500	1750	2000	2500	1735	1745	2888	2998	3188	4014	4114	4204	4304	6/8
M300	3000	1000	1500	1750	2000	2500	1985	1995	2920	3030	3220	4060	4160	4250	4350	6/8
M330	3300	1000	1500	1750	2000	2500	2135	2145	2940	3050	3240	4086	4186	4276	4376	6/8
M350	3500	1000	1500	1750	2000	2500	2235	2245	2953	3063	3253	4104	4204	4294	4394	6/8
M370	3700	1000	1500	1750	2000	2500	2335	2345	2965	3075	3265	4122	4222	4312	4412	6/8
M400	4000	1000	1500	1750	2000	2500	2535	2545	3014	3124	3314	4182	4282	4372	4472	6/5
M425	4250	1000	1500	1750	2000	2500	2660	2670	3030	3140	3330	4205	4305	4395	4495	6/5
M450	4500	1000	1400	1600	1900	2300	2785	2795	3046	3156	3346	4228	4328	4418	4518	6/5
M500	5000	1000	1200	1350	1800	1950	3035	3045	3079	3189	3379	4273	4373	4463	4563	6/5
M550	5500	900	1100	1200	1400	1550	3335	3345	3140	3250	3440	4351	4451	4541	4641	3/3
M600	6000	800	800	850	950	1100	3585	3595	3172	3282	3472	4397	4497	4587	4687	3/3

NOTE: (1)* refers to rated capacity with widen tires;

WIDE VIEW FULL FREE 2-STAGE MAST

mast model	Max. lifting height (mm)	load capacity (load center 500mm) (kg)					mast overall height (mm)		free lifting height (with backrest)(mm)		service weight (kg)						mast tilt angle (°) α/β	
		1t	1.5t	1.8t	2t	2.5t	1-1.8t	2-2.5t	1t	1.5t	1.8t	2t(GC)	2t(GD)	2.5t(GC)	2.5t(GD)			
ZM200	2000	1000	1500	1750	2000	2500	1485	1495	478	447	2900	3010	3200	3980	4080	4170	4270	6/8
ZM250	2500	1000	1500	1750	2000	2500	1735	1745	728	697	2932	3042	3232	4026	4126	4216	4316	6/8
ZM300	3000	1000	1500	1750	2000	2500	1985	1995	978	947	2966	3076	3266	4075	4175	4265	4365	6/8
ZM330	3300	1000	1500	1750	2000	2500	2135	2145	1128	1097	2988	3098	3288	4104	4204	4294	4394	6/8
ZM350	3500	1000	1500	1750	2000	2500	2235	2245	1228	1197	3003	3113	3303	4123	4223	4313	4413	6/8
ZM370	3700	1000	1500	1750	2000	2500	2335	2345	1328	1297	3015	3125	3315	4142	4242	4332	4432	6/8
ZM400	4000	1000	1500	1750	2000	2500	2535	2545	1528	1497	3063	3173	3363	4205	4305	4395	4495	6/5
ZM425	4250	1000	1500	1750	2000	2500	2660	2670	1653	1622	3082	3192	3382	4229	4329	4419	4519	6/5
ZM450	4500	1000	1400	1600	1900	2300	2785	2795	1778									